

Dragonfly Motif

Anchor

Materials Required

Anchor Stranded Cotton: 1 skein each of 305 Antique Gold and 255 Parrot Green (Art. no. 4635000-)

Coats Ophir: 1 spool of 300 Gold (Art. no. 4561000-)

Anchor Lame: 1 skein of 303 Yellow Gold (Art. no. 4180000- use 1 strand)

Coats Reflecta: 1 spool of 313 Lime Green (Art. no. 4563000- use double thickness)

One piece of fine woven fabric for background (or cushion cover, voile curtain, etc...)

One piece of craft felt measuring 5 cm x 8 cm for padding

One piece of Vilene Stitch 'n' Tear, 19 cm x 21 cm (REF. 982)

Dressmakers tracing paper (611282) and tracing wheel (611271) or Prym water-soluble Trick marker pen (611807)

Anchor 6" embroidery hoop (D248)

Prym/Milward embroidery needle No. 8 (A201)

Sharp embroidery scissors

Sharp awl (if making wire wings)

Picture frame and mount (optional)

Wire Wings Version only: 2 pieces of 6mm gold wire, each 15 cm long and craft glue



Anchor

Instructions

Work your embroidery following Freestyle diagram and order of working (the numbers correspond to the numbers on the Freestyle diagram), noting to work all parts similar to numbered parts using the same technique and same shade.

The design is worked throughout using Buttonhole Stitch, Back Stitch, Cross Stitch, Straight Stitch, Fly Stitch, Couching, French Knots and Satin Stitch.

Transfer the design

Please note to only trace the lines of the upper wings if not working the wire wings.

Either place the Outline diagram centrally underneath the fabric and trace the design through the fabric with the Trick marker or if using carbon paper transfer the Outline diagram onto fabric by first placing the dressmakers carbon paper centrally face downwards on the fabric then place the diagram face up centrally over the top.

Hold carefully in position and finely trace the outlines from the Diagram using a sharp pointed pencil or tracing wheel.

Iron the fabric to remove any creases. Place Vilene Stitch 'n' Tear under the fabric and place both in the embroidery hoop with the design central.

Order of working

(The numbers on the Freestyle diagram correspond to the numbers below. If the number is not on the Freestyle diagram there is a separate numbered diagram to explain the technique).

Cut out the felt templates and stitch them in position using small stitches, starting with piece 1 and working through to piece 4. The contours should lie smoothly.

Work the veins of the Wings using 1 strand of Lame following Fly Stitch on Wings Diagrams. Work only the Lower Wings if wire is to be used for the Upper Wings.

Couch the Ophir all round outer edges of Wings using 1 strand of 305.

Work Satin Stitch along lower body using 2 strands of Stranded Cotton shade 255.

Work Cross Stitch across lower body using Reflecta 313 double thickness.

Work Back Stitch in Reflecta 313 all round outer edge of lower body.

Work legs in Straight Stitch using Reflecta 313.

Work the wire wings if desired: bend the wire to the same shape as the Wire Templates, make a large hole in the fabric where the small black dots appear on the Outline diagram and plunge each end through. The dotted lines on Wire Template show how far to plunge the ends. Bend over on the reverse a couple of times and oversew in place to previous stitching.

Work very loose Buttonhole Stitching in Ophir 300 around wire wings as in the Buttonhole Stitch Wings diagram – secure the thread along the wire with a small blob of craft glue. Secure ends of Ophir on reverse.

Using Stranded Cotton 305, couch down Ophir 300 on top part of body, starting from the outside of the circle, working inwards to the centre.

Work French Knots all over Head, using Reflecta 313.

Work French Knots for eyes using Ophir 300.

On completion of embroidery remove from hoop. Place face down on thick towels and iron to remove any creases from the hoop. Remove Stitch 'n' Tear backing.

To mount in a frame

Place embroidery centrally over backing board, fold surplus fabric to the back and secure at top with pins into edge of board.

Pull firmly over lower edge and pin in position.

Repeat on side edges pulling fabric until it lies taut on the board.

Secure at back by lacing from side to side both ways with strong thread.

Remove pins and frame as desired.

OUTLINE DIAGRAM (actual size)

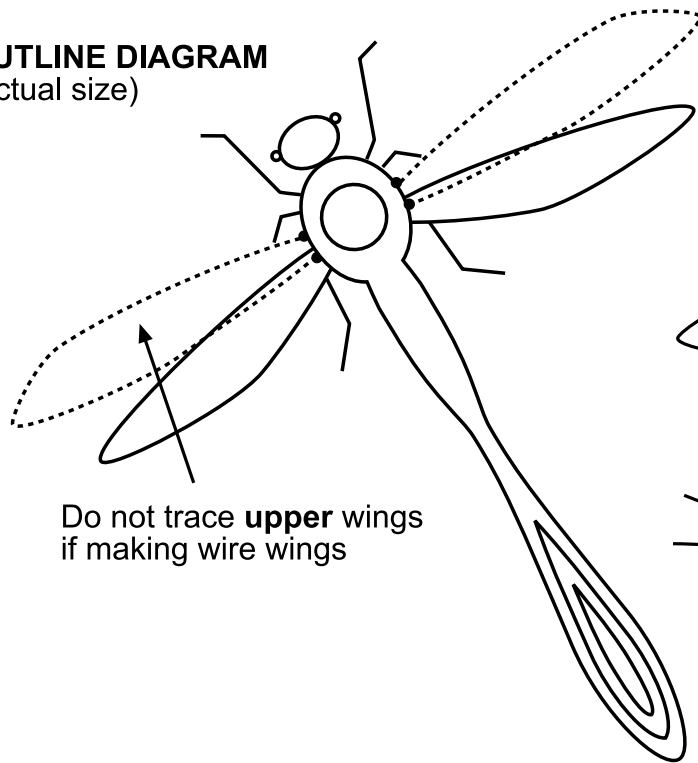

Do not trace **upper** wings
if making wire wings

8. Wire Templates

Left Upper Wing



Right Upper Wing



FREESTYLE DIAGRAM (larger than actual size)

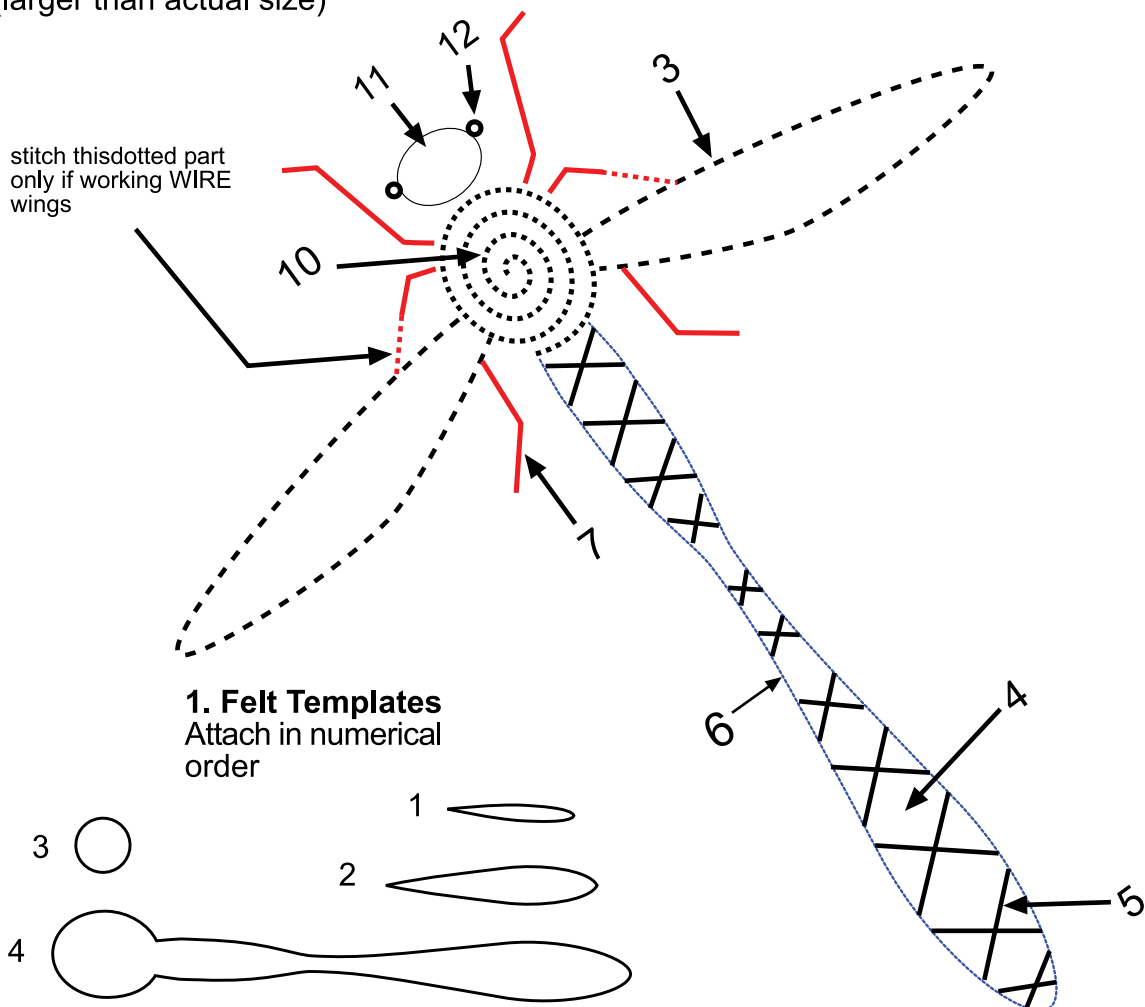

1. Felt Templates Attach in numerical order

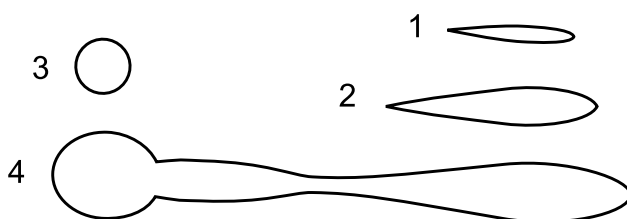

2. Fly Stitch on Wings

Upper Left Wing
(if not using wire)

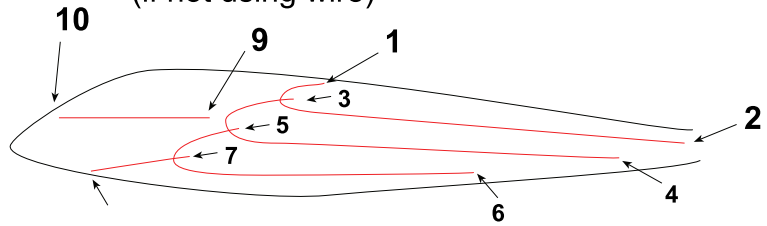

Upper Right Wing 1
(if not using wire)

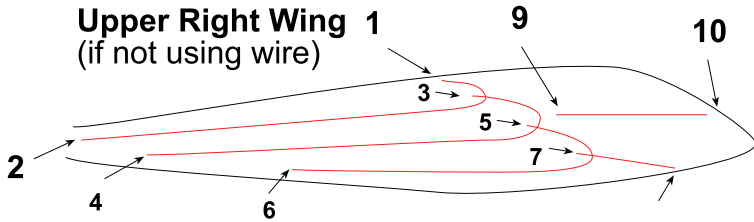

Bring needle out to right side of fabric on odd numbers and take back through to wrong side on even numbers, starting with 1.

Lower Right Wing

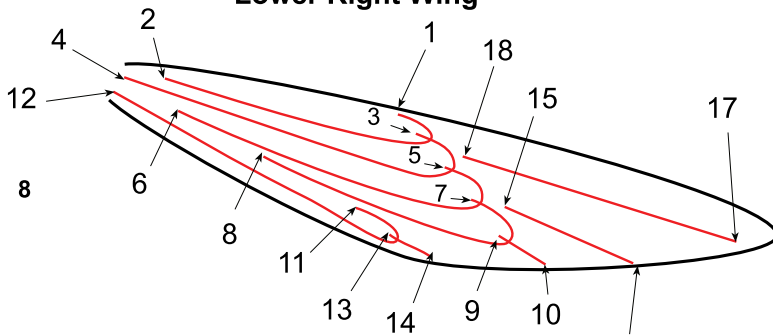

Lower Left Wing

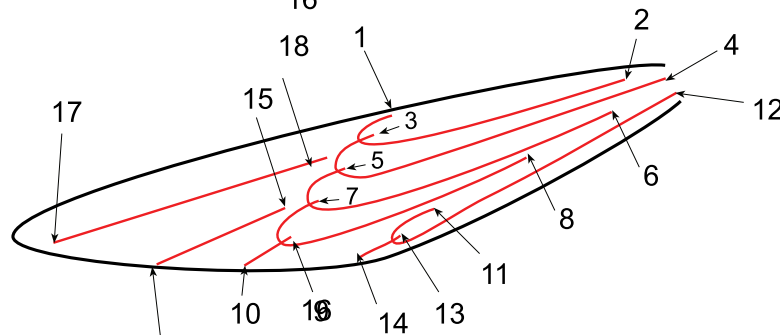

8

9. Buttonhole Stitching (on wire wings only)

Left Wing

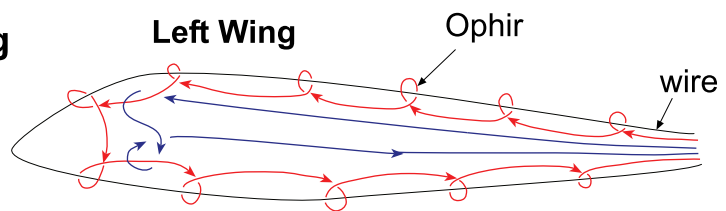

Right Wing

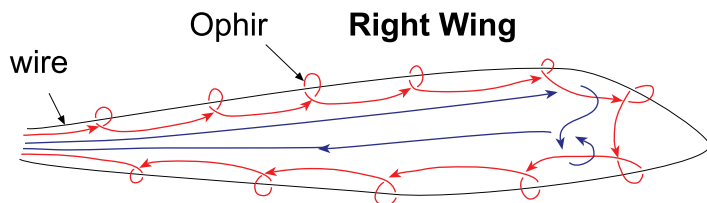

→ = first row of stitching

↻ = second row of stitching